

Harcourt Terrace



Educate Together
National School



Information Booklet 2024 – 2025

Educate Together Learn Together to Live Together



Welcome Booklet



**“Education is the most powerful weapon which
you can use to change the world” Nelson
Mandela**



Welcome from Tony

Tá fáilte romhaibh chuig Harcourt Terrace Educate Together National School. Tá súil agam go mbainfidh tú taitneamh agus eolas as an glcár seo. This booklet should give you a small insight into the wonderful opportunities afforded to the children who attend our school.

We are a welcoming and inclusive school where no child should ever feel like an outsider. We work in partnership with all parents/guardians to create a rich, engaging, and holistic learning environment for our children. Harcourt Terrace ETNS is a school where everyone can be themselves.

We are supported by an amazing Parent, Guardian & Teacher Association who contribute immensely to the success of our school. We value parental involvement and there will be opportunities for you to visit our school, to support your child/children's learning journey.

We are currently located in our temporary home in Rathmines, as we await our state-of-the-art building in Harcourt Terrace, which is due to be completed for this coming September.

We are all extremely proud of our pupils and are constantly amazed by their abilities and talents. We will endeavour to continue to nurture and develop their skills, knowledge and understanding of the world around them. We look forward to what the future will bring for our community in Harcourt Terrace ETNS.

With every good wish for the year ahead,

Tony Walsh
Principal



Educate Together

Harcourt Terrace Educate Together National School has been established under the patronage of Educate Together. Educate Together runs schools that guarantee equality of access and esteem to children "irrespective of their social, cultural or religious background", are learner centred in their approach to education and are run as participatory democracies, with respectful partnership between parents, pupils, and staff.

Educate Together schools are guided by four main principles. They are:

Child-centred

Our school aims to create a learning environment that nurtures and encourages all children so that they may explore their full range of abilities and reach their highest potential. Children in our school have a right to have their voice and opinions heard and decisions in our school are always taken in the best interests of the children.

Equality-based

The Educate Together school model is based on equality and human rights. Educate Together schools provide a learning environment that is safe and supportive of the identity of every child.

Co-educational

The school is open to boys and girls on an equal basis. Every effort is made to avoid and challenge gender stereotyping both in attitude and teaching materials.

Democratically run

The school is run by management committees that are democratically elected and run and the involvement of parents is sought and encouraged. Children will contribute to school management throughout their time in our school through a variety of platforms such as student council, green schools, and playground committees.



School Management

Board of Management

Our school is governed by the Board of Management. This democratically elected committee of eight people has the responsibility to ensure that our school is run effectively, in keeping with the four main principles of Educate Together. The Board of Management is the decision-making body in the school and consists of 8 members. Each Board of Management serves a four-year term. Our chairperson is Sylvia O'Halloran. More information about our Board of Management can be found at <https://htetns.ie/about/board-of-management/management/>



Parent, Guardian and Teacher Association

We have a newly established Parent, Guardian and Teacher Association (PGTA). The PGTA organises a number of events throughout the year for children and parents. It also supports the school by helping to create and review policies. Please consider lending a hand to the work of the PGTA. It is vital for our school community. Any queries can be directed to the PGTA and emailed to pgta@htetns.ie

Meet the Team 2024/2025:

Tony	Principal
Sophie	Deputy Principal & Junior Infant Teacher
Rachel	Junior Infants Teacher
Caitríona	Senior Infants Teacher
Aaron	1 st class Teacher
Ashleigh	2 nd Class Teacher
Aoife	Assistant Principal II & 3 rd Class Teacher
Keith	4th Class Teacher
Fiona	5 th Class Teacher
Rachael	Autism Class Teacher
Shane	Autism Class Teacher
Maeve	A.E.T Teacher
Meadhbh	Assistant Principal II & A.E.T Teacher
Seánín	A.E.T Teacher
Ella	A.E.T Teacher
Anna	A.E.T Teacher

Ciara- Jamie covering	A.N.A
Ann	A.N.A
Hannah	A.N.A
Nina	A.N.A
Brighid	A.N.A
Jeanette	A.N.A
Barbara	A.N.A
Brigid	A.N.A
Sarah	A.N.A
Sineád	A.N.A
Molly	School Secretary
John	School Caretaker



Welcome from Sophie:

Hi, my name is Sophie, and I am the Deputy Principal of Harcourt Terrace ETNS. I am the additional educational needs coordinator in our school.

I work closely with the principal, assistant principal and all the staff of HTETNS to make our school welcoming, inclusive and fun!

My door is always open, and I am available to have a chat and answer any questions or queries.

I look forward to meeting all the new students coming to Harcourt Terrace ETNS.



Welcome from Meadhbh:

Hi, my name is Meadhbh, and I am an Assistant Principal II here at Harcourt Terrace ETNS. I am a Froebel trained teacher with experience teaching both in Ireland and internationally.

I believe in creating a welcoming classroom and school environment, where children feel supported and celebrated, with their individual interests encouraged and developed.

I work with Tony, Sophie and all staff to help deliver a high standard of teaching and learning for all our students. I am always available to answer your questions or help where possible.

I am so looking forward to meeting the new students this year. I know you are going to love it here!



Welcome from Ashleigh-Rose:

Hello, my name is Ashleigh-Rose, and I am an Assistant Principal II here at Harcourt Terrace ETNS.

I completed my Professional Master of Education at Hibernia College and have worked in various educational settings both in Ireland and internationally.

I work diligently and collaboratively alongside Tony, Sophie and all staff at Harcourt Terrace to create a warm and exciting environment for children to learn.

My goal is to enable our students to grow independently, explore their true passions and build meaningful friendships at school.

I am really looking forward to welcoming both new and returning students this year. Please do not hesitate to stop and talk to me if you have any questions. I am always happy to help!

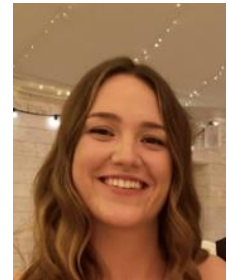

Welcome from Aoife:

Hi, my name is Aoife, and I am an Assistant Principal II at Harcourt Terrace ETNS.

I am a Froebel graduate and have spent many years teaching in schools around Dublin and in the UK. I have lots of experience of teaching senior classes in primary school.

I work with the rest of the leadership team to support teaching and learning across the whole school, especially in the STEAM subjects.

I am very excited to meet all the new students in September and welcome them to our school!



Home-School Communications

Contacting the school

It is important for you, and for your child that we keep in regular contact in regard to your child's experiences at Harcourt Terrace ETNS. If you have any queries, worries or concerns, or, if you need to inform us of something important, please do not hesitate to get in touch.

The start of the school day is a very busy time as our teachers welcome the children into their class and help them to settle. So can we respectfully ask you to contact us in one of the following ways:

By email: info@htetns.ie

By phone: 01 5292970 between 8am - 4pm, Monday – Friday.

Our secretary, Molly, works from 8.30am-2:30pm, so outside of these times, we might be slower responding!



School - Home Messages

We are a Green School and communicate with parents' principally through email and from time to time, we may communicate via text. **Please ensure the school has your most up to date contact information and let us know if your details change during the year.**

The school will issue regular newsletters to keep parents informed of school activities, achievements and exciting news. These will be sent via email from our Aladdin Schools database system. We use **Aladdin Connect** which allows all parents will be able to communicate with us through the APP on your smartphone. We will send out log-in details on our return to school at the end of August.



Absences

It is not necessary to ring the school if your child is absent, however, **all absences must be explained via Aladdin Connect on the day your child returns to school.** As a school we abide by the Education and Welfare Act 2000. Under this act we are obliged to report absences that exceed 20 days in one school year. We also mark children as being late if they are present in school **10 minutes after our 8:30AM** start time. We encourage all children to be in school at 8:30AM to minimize any loss in teaching time.



Encouraging Healthy Eating

We encourage all children to bring healthy lunches to school each day. Parents and guardians are asked not to send in crisps, bars, cakes, sweets, fizzy drinks, biscuits or chocolate in lunchboxes during the week. It is essential to be mindful of children in the school who have a nut & sesame seed allergies so **please do not include any nuts in your child's lunch.** We are a nut free school. Under the discretion of the school principal, there may be events where treats are allowed to be brought into school. In these cases, parents will be informed in advance. Due to Covid-19 as well as prevention of allergies we do not accept food in from home to share with other children in the class. Children are welcome to drink water whenever they need it during the school day. However, other drinks (juice etc.) are only permitted at break times.

Lunch Boxes and Bottles

Let's teach the children the importance of recycling and please only give them re-usable containers and bottles for lunch.



Birthday parties

Birthdays are so important for children, but we do not celebrate birthday parties in our school. We will treat it as a special day and celebrate it in the class. We will make a fuss! But children are not allowed to bring in cakes or hand out invitations. This is due to allergies which means we cannot share food. It also alleviates the pressure that hosting a party can bring for families.



Positive Behaviour

Our school is a restorative practice school.

This means that we strive to build positive relationships, working to solve conflict together. Our staff have undergone training in restorative practice and promoting positive behaviour. We are currently building this into our daily practice as part of our Code of behaviour. This approach to living and learning ensures that our school is inclusive, calm, and built on a strong sense of responsibility and community.



Child Protection

The school operates a Child Protection Policy under the Children First Guidelines. Anyone with concerns about the welfare of children should report directly to the Designated Liaison Person (DLP).

The DLP for this school is Tony Walsh.

The DDLP for this school is Sophie Adams



Health and Safety

As the school grows, we will always endeavour to ensure the school is a safe place for all who attend, visit or work here. If you have any concerns in relation to Health and Safety, please report them to Tony or Sophie (Deputy Principal).



Schoolbooks Grant

The cost of preparing children for school each year can be a challenging and worrying time for many families who are under increased financial pressure. The Department of Education and Skills have setup a grant scheme for all primary school children in Ireland, covering any costs related to schoolbooks, copybooks and workbooks. The school will be providing all stationary materials for children in all classes. Your school fees cover all additional costs for this.

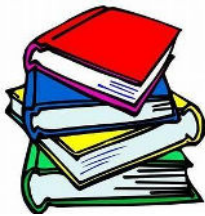

Book Rental

The book rental scheme will provide books that can be reused in the school. Examples of these books are the reading books that the children use. These will be levelled readers such as Oxford Reading Tree, Engage readers, PM readers and the class core readers from the Starlight programme (Folens). We ask that the children take good care of these books when they take them home as part of their homework. The children must ensure their rented books remain in their folder while they are in their schoolbag.

One of our golden rules is:

“We look after property”

School fees for the relevant necessities:

All fees are due for payment in advance of starting school on the first day.

Item	Amount Due
Insurance	€10.00
Digital Learning	€10.00
Membership of Educate Together	€15.00
Photocopying	€30.00
Visual Arts	€25.00
Classroom Stationary	€20.00
Total	€110.00

All payments will be made through our Aladdin epayment facility which we will be in touch via email to setup.



Aladdin
The Software Behind Great Schools



A note about Insurance:

Allianz Pupil Personal Accident Insurance covers your child 24/7 and not just when your child is in school. **Please be aware that your child is not covered under this insurance scheme until the school fees are paid.** For further information about this insurance cover or how to make a claim against it please visit:

<https://www.allianz.ie/pupil-personal-accident/claims/>



What your child needs to bring to school:

- We will provide all books, copies and stationary for all children in our school.
- We only ask that your child brings a **schoolbag, pencil case, coat, lunchbox and drink** with them to school each day.





HARCOURT TERRACE
EDUCATE TOGETHER
NATIONAL SCHOOL

What Harcourt Terrace ETNS can offer your family:

- A warm, caring and welcoming environment
- Brand new state of the art school building
- A full size PE hall
- Sensory Room
- Outdoor play spaces
- Nurture room
- Onsite after-school service on a daily basis
- Full after-school activities program
- Soft play area
- Garden area
- Active school
- Green school
- Digital School
- Creative school
- Full suite of supports to help your child to grow and learn!

Curricular Programmes & initiatives in Harcourt Terrace ETNS



The curricular programmes we offer in are always chosen with our children in mind. We always opt for programmes that are visually stimulating and interactive. Above is a selection of the core programmes which our talented staff use daily in their lessons, bringing learning to life. We use digital technology in all classrooms which really helps to enhance the children’s learning experiences. Our aim is that the children have so much fun in Harcourt Terrace ETNS that they won’t even realise that they are learning!



Harcourt Terrace ETNS is a nurturing school which places the children’s social, emotional, mental, and physical well-being at the centre of everything that we do. We pride ourselves on the wonderful Nurture room we have developed and our forward-thinking approach that helps all of the children in Harcourt Terrace ETNS to grow. Recently we were awarded Amber Flag status for our innovative approach to supporting well-being across our whole-school community. We are a green school, and we really care deeply for the environment around our school. We place huge emphasis on outdoor learning at every opportunity. Our Student Council and Green school Team help us to make our school a centre of learning excellence. We really value student voice. There is a saying, “Nothing about us without us”. The children are always included in decisions that affect them.

Co-curricular & Extra-Curricular Activities



We provide a variety of different extra-curricular activities after school each day. Our mission is to provide each child in Harcourt Terrace ETNS with a daily option over the course of the week. Currently we have:

Monday: Artzone & Indoor Games

Tuesday: Catch Dance Academy & STEAM Academy,

Wednesday: Lightning Legs Multisport Club,

Thursday: Olé School of Languages & Music Club

Friday: Soccer Club & Piano Club



We also have developed partnerships with some local organisations who provide sporting opportunities as part of our PE programme in the school. St. Kevin's GAA Club and Ranelagh Gaels GAA Club provide GAA coaching throughout the year. Leinster Rugby have recently come on board to provide rugby coaching. Our senior classes will go swimming at Swan Leisure Centre every year. As well as that we use the fantastic sporting facilities in Swan Leisure when needed. The children in our school get to avail of some great opportunities locally!



After-school club at Harcourt Terrace ETNS

We have a full-time afterschool programme on our school site in Harcourt Terrace ETNS, which takes place when classes finish and continues up to 6.30pm daily. Your child can unwind in a relaxed, safe and fun, home from home environment which is part of the school community. This programme is run by Kids Inc. and plays an important role in the social and emotional development of our children. It is not intended to be an extension of our school day. Everything is child led and there are a wide range of creative and physical activities that children can tap into throughout the afternoon. Kids Inc. offer homework supervision, which is a big plus for parents and children, as it allows for a more relaxed end to the day for all. They provide healthy nutritious meals and snacks devised to follow the Department of Health's Food and Nutritional Guidelines. Website: <http://www.kidsinc.ie/>

Phone: 01-6215790

Email: info@kidsinc.ie

Sample of a daily routine, children can choose from a wide range of activities

Time	Group 1	Group 2	Group 3
2.30pm – 3.15pm	Healthy Snack + Homework	Healthy Snack + Homework	Healthy Snack + Homework
3.15pm -4.30pm	Creative Activities – Art projects, Speech & Drama, Imagination Games, Music, Singing, Creative writing , Quizzes Physical Activities – Obstacle Course, Team Games, Soccer, Tennis, Bowling, Dance		
4.30pm – 5.00pm	Dinner/Snack	Dinner/Snack	Dinner/Snack
5.00 pm – 6.30pm	Creative activities – Board Games, Puzzles, Crafts, Language/Fun Quizzes, Reading, Lego Construction Physical Activities – Relay Races, Tag Rugby, Gymnastics, Yoga, Karate, GAA		



Our New School Building

We will move to our new permanent home at Harcourt Terrace in September for the 2024/2025 academic year:



HARCOURT TERRACE EDUCATE TOGETHER NATIONAL SCHOOL

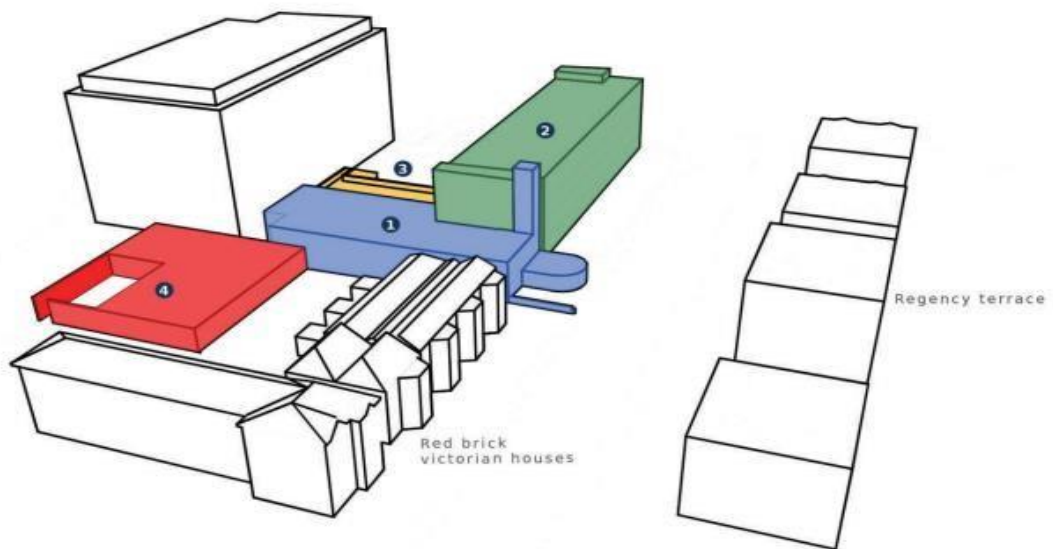

- 1 Two storey entrance block
- 2 Four storey classroom block
- 3 GP Hall, partly in basement
- 4 Single storey Special Educational Needs Unit



GROUND FLOOR PLAN

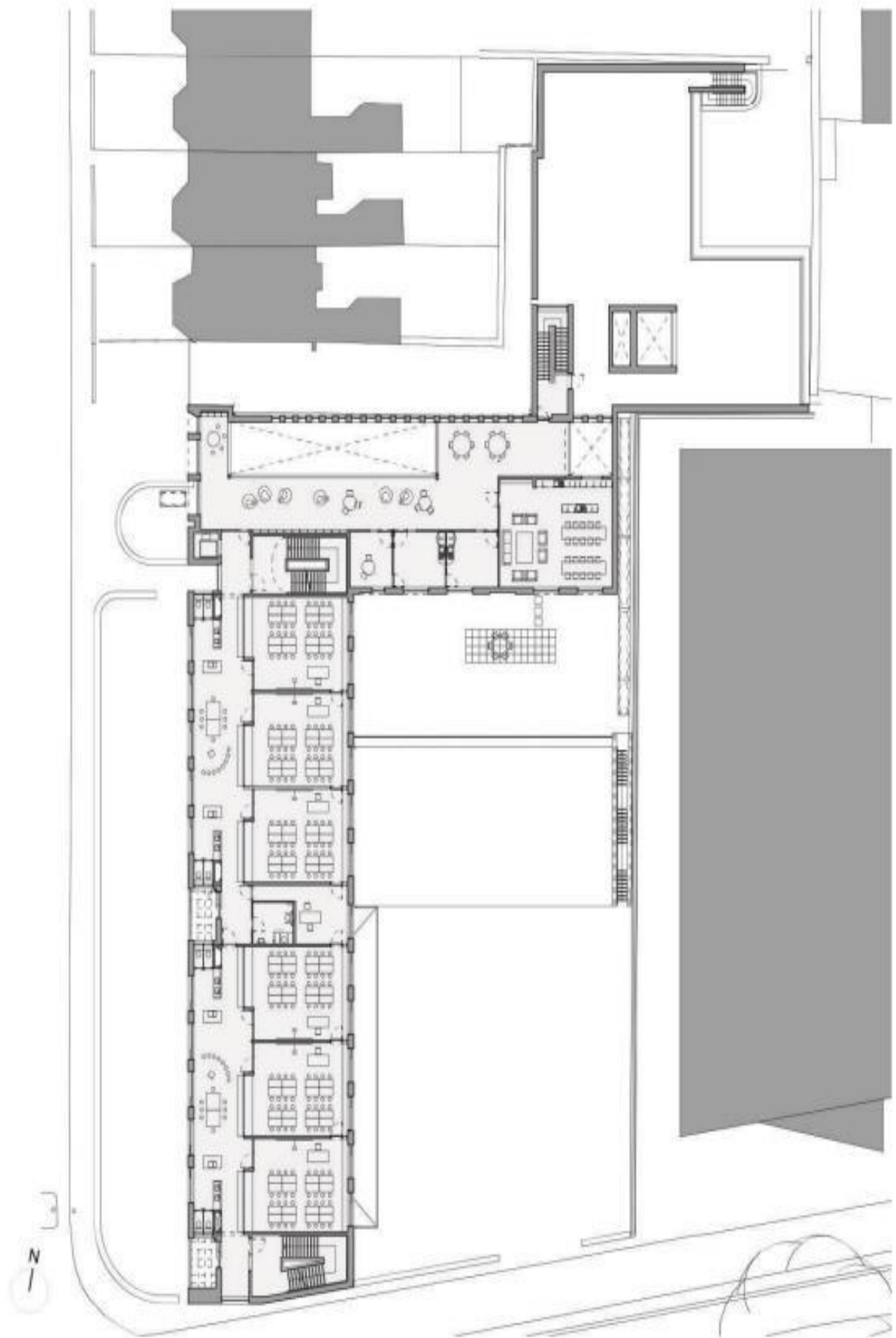

FIRST FLOOR PLAN



1. Entrance (competition image)

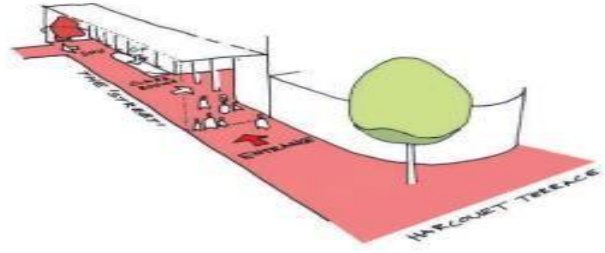

2. Sketch of entrance spaces



3. Entrance Space (competition image)

The school is entered from the northern end of the site off Harcourt Terrace.





2. GP Hall (competition image)

The general purpose hall is located in basement level at the northern end of the site. It can be accessed from two levels via the entrance space, and from the main play space via an amphitheatre allowing it to function as a covered play space.



1. Play Space (competition image)

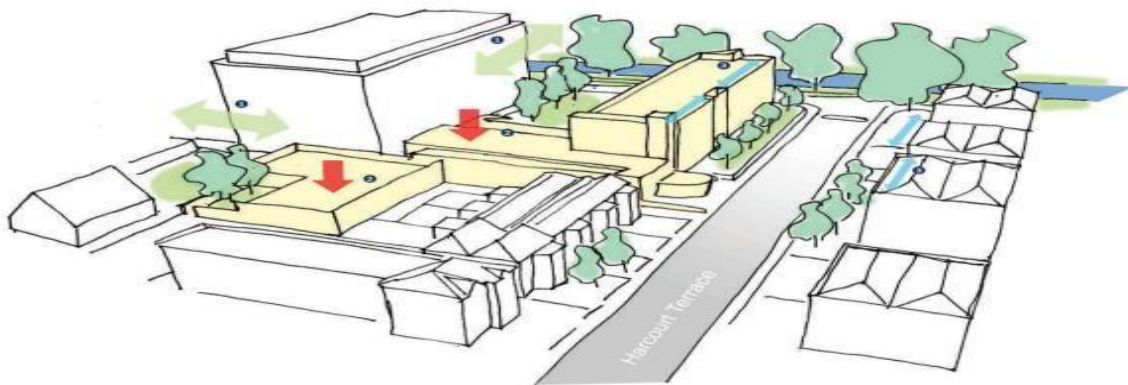

1. Connections to existing green spaces
2. Building volume lowered next to adjacent properties
3. Main volume designed to respect scale and grain of existing context

When Your Child Starts School On the first day:

- Have everything ready the night before to reduce last minute panic (e.g., school bag packed, clothes out, plan for breakfast).
- Leave plenty of time so you arrive a few minutes before school starts at **8.30am**. This will help you and your child arrive to school relaxed.
- Reassure your child and talk about the fun they will have in school.
- Try not to let your child see if you are upset and don't hang around for too long on the first morning as this could unsettle your child.
- Make sure your child knows who will be collecting them and where.



Going forward:

- If you have any concerns about your child, contact the school immediately (do not wait!). We use Aladdin Connect for all communication in Harcourt Terrace ETNS. You can also arrange a meeting with the teacher through our school secretary Lori.
- Attend coffee mornings and other PGTA events. There you will learn more about us, and what you can do to support your child at home and to meet other parents.
- Arrange for your child to arrive and be collected on time. This may involve changing your daily schedule if you work or seeking support from family members/ friends

Top Tips to Develop Your Child's Skills for school:

The more your child practices relevant skills at home the more he/she will be prepared to participate in real world situations in school. Try to introduce these skills naturally during your child's day at home.

- **Encourage self-care skills and independence:** Washing hands, putting on their coat, putting on their shoes (Velcro shoes please) putting things into their bag.
- **Develop gross motor skills (using big muscles in the body):** Pulling & pushing things, sports activities, obstacle courses.
- **Develop fine motor skills (using small muscles in the hands):** Scissors activities, colouring, writing, lego, playdough, clothes pegs.
- **Develop their communication skills:** Listening games, develop conversations with your child.
- **Read with your child:** Regular access to reading material as part of the daily routine.
- **Play with your child:** Develop their imagination through playful activities.



School Times

We believe the best introduction for your child is to stagger them in over a 2-week period to get used to the longer day from pre-school/home-schooling.

Week 1 Junior Infants

Wednesday, 28th August – Friday, 30th August 2024

8:30am – 11:30am (small break only)

Week 2 Junior Infants

Monday, 2nd September – Friday, 6th Sept. 2024

8:30am – 11:30am (small break only)

Week 3 Junior Infants

Starting Monday, 9th of Sept. 2024:

8:30am – 1:10pm (full day)

Senior Infants- begin the year on full days from 8.30am-1.10pm.

1st-5th class begin the year on full days from 8.30am-2.10pm

School Calendar 2024-2025

School Opens: Wednesday 28th August 2024.

Mid-Term Break: School Closed Monday 28th of October to Friday the 1st of November (inclusive).

Re-opens: on Monday 4th of November 2024.

Winter Break: Friday 20th of December - School Closes at 12pm.

School closed: Monday 23rd of December to Friday 3rd of January (inclusive).

Re-opens on Monday 6th of January 2025.

February Bank Holiday: School Closed Monday 3rd of February 2025.

February Mid-Term Break: School Closed Monday the 17th to Friday the 21st of February 2025.

Re-opens: on Monday the 24th of February 2025.

Public Holiday: Monday the 17th of March (St. Patrick's Day).

Spring Break: Friday the 11th of April - School Closes at 12pm.

School Closed: Monday 14th of April to Friday 25th of April (inclusive).

School re-opens: Monday the 28th of April 2025.

May Bank Holiday: School Closed Monday the 5th of May

June Bank Holiday: School Closed Friday 30th of May, Monday 2nd of June & Tuesday 3rd of June.

Summer Break: Last day of term is Friday the 27th of June 2025. School Closes at 12pm.

